



Wennington Road, Southport PR9 7TN. England
Tel: 01704 518000 Fax: 01704 518001
WEB SITE <http://www.unipartdorman.co.uk>
E MAIL address – dorman.info@unipartdorman.co.uk

Health and safety

Every effort has been made to ensure the accuracy of the information given in our publications, but in accordance with our policy of continually improving our products we reserve the right to modify designs and specifications whenever necessary. All equipment is designed to conform to relevant British and International standards. Every care is taken to ensure that, as far as reasonably practical, it will perform without risk to health. It is essential that accepted codes of professional practice are followed in the assembly, installation and commissioning of the equipment. If in doubt with respect to any of these instructions, please consult Dorman before installing the device.

Dorman reserves the right to vary any component part to meet the required specifications without prior notice.



Certificate No. FM 14371

Dorman ref. No C64.63477 Iss4

Miniature Stop Light (MSL) Installation Instructions

To be read before commencing
Operation



Installation Instructions

ALWAYS TURN OFF ELECTRICITY AT MAINS BEFORE COMMENCING WORK

General.

In general before commencing assembly, any local safety requirements affecting the safe working environment of the signalling installation either directly or indirectly should be carried out.

When the MSL is fully assembled, the user should note that the unit weighs a maximum of 17Kg. It is the users responsibility to ensure that, if the MSL is to be lifted then suitable certificated lifting apparatus and/or other precautions are employed.

The MSL should only be assembled both electrically and mechanically, by staff deemed competent in these fields by their employer.
The installation standards of the indicator should follow the general provisions of the Signalling Installation Handbook

The MSL is affixed to the support post (ref.BRS-SM 97) using its own integral post clamping block arrangement.

Unlock the main locking bolt, open hinged cover to reveal the post clamping block. Unscrew the 4 off M6 socket head bolts to remove clamping block. Mount MSL unit onto the mounting post ensuring the top ring of the post is located in upper chamber above the clamping block area.

Locate and secure clamping block using the 4 off M6 socket head bolts (refer to clamping torque setting below).

Before tightening the clamp bolts, align MSL to correct position.

When tightening clamp bolts, ensure the clamping block is kept square to main MSL body and tighten each bolt gradually as sequence shown until required torque is reached.

When the MSL is mounted correctly, the three M8 centrally mounted screws in the clamping block may be tightened (refer to clamping torque setting below).

Clamping Torque Settings

4 Off - M6 Socket Head Screws – 5mm A/F Hex bit (Clamping Block) – 6.8Nm
3 Off – M8 Grip Screws – 4mm A/F Hex bit (Middle of Clamping Block) – 6.8Nm

Electrical Connections.

Access to the terminals to allow the wiring of the indicator signalling circuitry is effected by unlocking the main locking bolt. The MSL cover can then be hinged open.

The incoming cable to the MSL is routed to the terminal blocks through a gland at the bottom of the terminal chamber. When tightened, this gland will complete the sealing of the enclosure.

Within the terminal chamber, standard 2BA stud blocks are provided. Links are labelled as per the wiring diagram label affixed to the inner face of the terminal box.

PIDG ring crimps on each conductor locked down by 2BA nuts should be used in order to connect the tail cable to the stud block.

Temporary disconnection of each circuit may be achieved by use of sliding 2BA links.

When wiring is completed the cover can be located back onto the main body and main locking bolt tightened

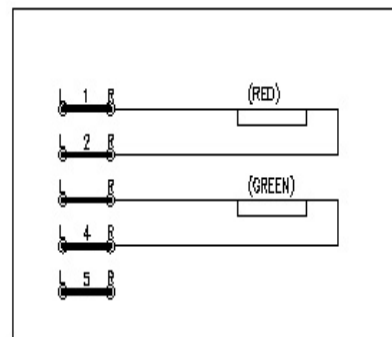

MSL connection arrangement

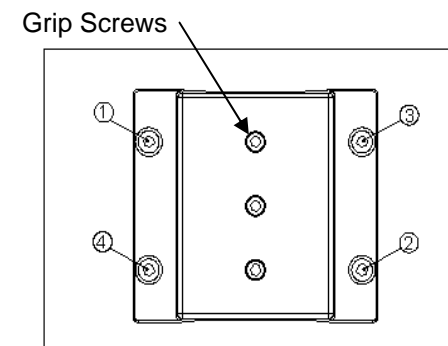

Clamp tightening sequence

Approvals and Specifications.

Part No.	MSLH2/RG/1/P/G (Diagram 107) MSLC2/RG/1/P/G (Diagram 108)
Sign Reference	The Private Crossings (Signs and Barriers) Regulations 1966, diagrams 107 and 108.
Acceptance Number	PA05/02619
Operating Voltage	Max 121 Vac: Min 88Vac Max 145 Vdc: Min 88Vdc
Nominal Operating Current	0.3A @ 110 Vac
Dust/Water Ingress Rating	IP54
Weight	17Kg