

Route Indicator Range



Unipart Dorman's LED Signaling Range:

With over 25 years of experience in LED Rail Signaling, Unipart Dorman has a complete range of Network Rail approved LED signals that are backwards compatible with the existing systems on the UK infrastructure.

This comprehensive range covers nearly 500 approved items to date and Unipart Dorman has in excess of 60,000 signals now installed across the network. Where Unipart Dorman LED signals have been installed, failures and delays associated with the signal heads have been virtually eliminated.

Unipart Dorman, Design & Manufacturing Capabilities:

Unipart Dorman's engineering heritage goes back over 130 years. The innovation and design-led business philosophy revolves around listening closely to customers and ensuring product development is always focused on their requirements. Unipart Dorman is a leading light in rail with extensive product ranges available throughout the UK and in more than 30 countries across five continents.

Unipart Dorman has been at the forefront of LED technology since the 1980's. LED lighting offers unrivalled safety and economic benefits when compared to filament bulbs and the company's technological leadership has resulted in several industry 'firsts', including ConeLITE, the industry-standard warning lamp for road hazards, and the Unipart Dorman Position Light Signal, introduced in 2000 and the first LED signal which controlled train movement fully approved by Network Rail to Railway Group Standards.

Unipart Dorman product and specifications subject to change and/or modification without prior notice.

The Route Indicator Range is just part of the wider portfolio of Unipart Dorman products which cover every part of the railway.

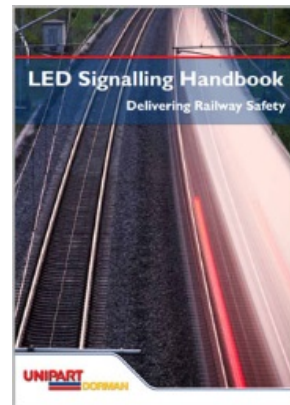

The LED Handbook contains full details of all the rail products. Contact us to receive your copy, or visit uniparttrail.com/ledhandbook for the PDF version

Contact Details:

Unipart Dorman's range is distributed through Unipart Rail:

Unipart Rail
Gresty Road
Crewe
Cheshire
CW2 6EH

Tel: +44 (0)1270 847600
E-Mail:

dorman.info@unipartdorman.co.uk

www.unipartdorman.co.uk



Alpha Numeric Route Indicators



The Alpha Numeric Route Indicators are a fully Network Rail approved cost effective direct replacement unit suitable for any installation with no requirement for on site design changes.

- Compliant with Network Rail Line Specification GK/RT0045
- Modular hinged assembly to enable ease of cleaning from a place of safety
- LED light sources designed to give a long and predictable service life
- Constant light output and colour is maintained throughout the life of the indicator
- Unaffected by variations in supply voltage 88Vac – 121Vac
- Compatible with existing SSI & RRI installations
- Directly interchangeable with existing fibre optic units
- LED displays sealed to IP65
- Nominal supply voltage 110Vac
- Reduced installation and maintenance costs



Route Indicator

Product Details

Benefits

- LED technology gives a long and predictable service life
- Miniature indicator readable to category 5
- Standard indicator readable to category 2
- Hinged assembly to enable easy cleaning and maintenance from a place of safety
- Standard and miniature indicators custom made to specific customer requirements

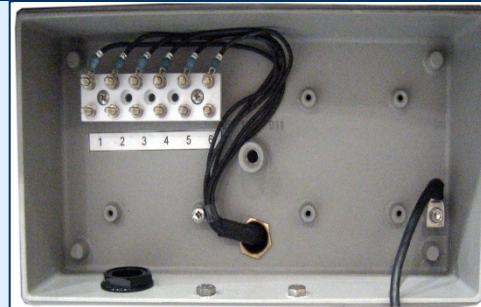

Indicator Maintenance

- The light sources hinge rearwards enabling installation and removal by a single operator using a simple lockable latch mechanism
- Maintenance required on LED Route indicators has been reduced to occasional cleaning only which significantly reduces costs



Standard Indicator

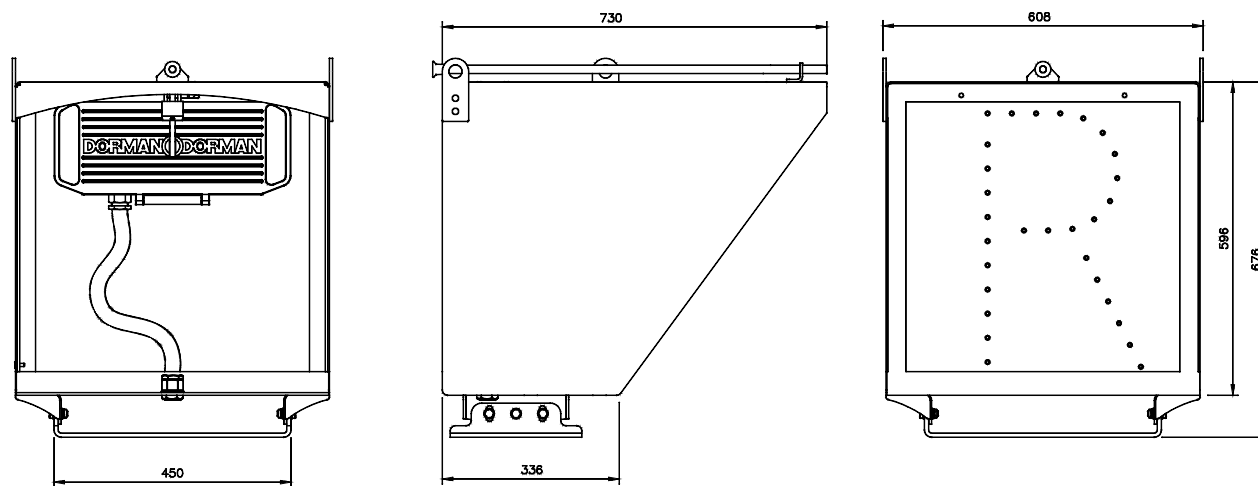

Miniature Indicator

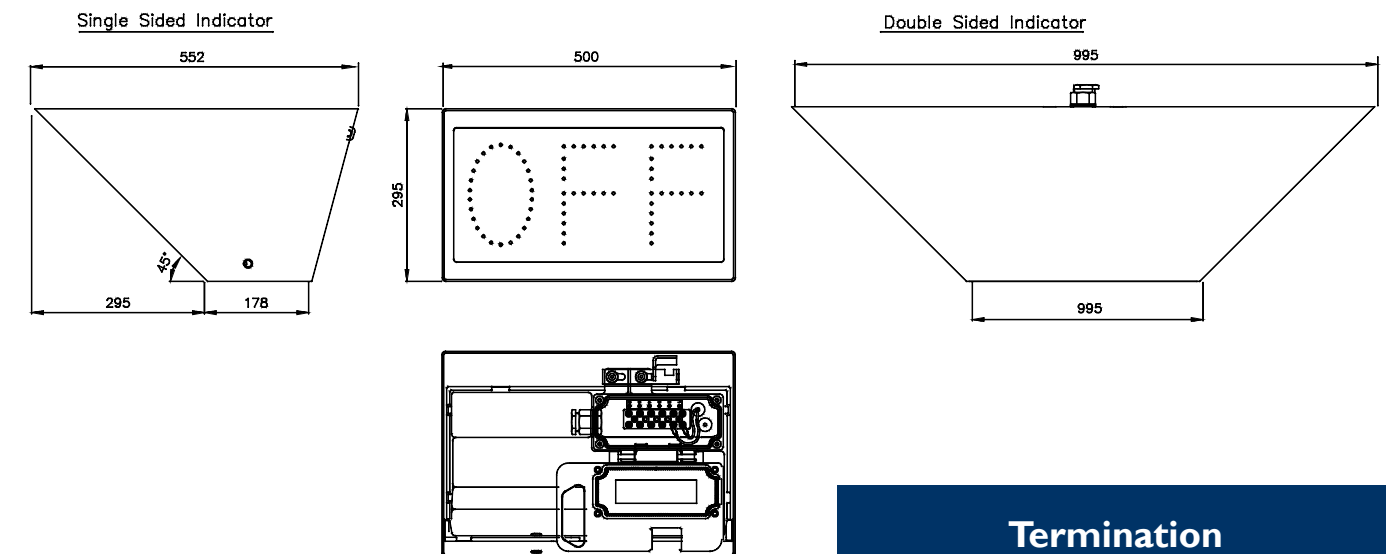

Lamp Proving

Both indicators are fully compatible with relay and SSI Lamp proving based on a current draw of 300mA.

Alignment

To enable alignment of the unit, vertical adjustments are made using the hinged tilting mechanism, and rotational adjustment is performed via the kidney slots in the signal base.

Network Rail Product Acceptance No:

PA05/01071 LED Miniature Route Indicator (Stencil)
PA05/2433 LED Standard Route Indicator (Theatre)

PADS No:

Standard Route Indicator with 1, 2, 3, 4, 5 or 6 Indication (Theatre)*	0086/021040
Miniature Route Indicator (Stencil), Single Sided, with 1, 2, 3 or 4 Indications*	0086/021020
Miniature Route Indicator (Stencil), Double Sided, with 1, 2, 3 or 4 Indications*	0086/021021
Miniature Route Indicator (Stencil), Single Sided "RA"	0086/021022
Miniature Route Indicator (Stencil), Single Sided "OFF"	0086/021023
Miniature Route Indicator (Stencil), Single Sided "CD"	0086/021024
Miniature Route Indicator (Stencil), Single Sided "CD + RA"	0086/021025

*For advice on the ordering detail for bespoke indications, please contact Unipart Dorman

Termination

The 110Vac supply can be terminated directly onto the standard 2BA terminal bar and slip link assembly at the rear of the unit.

Safety

The light weight hinged design enables all signal related maintenance to be performed from a position of safety.